

Water and sustainability

Practical Test

Paramecium - Fajans titration - Blue energy

December, 9th 2017

Carefully read the “EXAMINATION RULES” and “EXPERIMENT INSTRUCTIONS”



Radboud Universiteit



Hogeschool



van Arnhem en Nijmegen

slo

EXAMINATION RULES

1. You are NOT allowed to bring any personal items into the examination room, except for personal medicine or approved personal medical equipment.
2. You must sit at your designated table.
3. Check the stationery items (pen, calculator, ruler, and scrap paper) provided by the organizers.
4. Do NOT start your experiments before the “START” signal.
5. You are NOT allowed to leave the examination room during the experiment, except in an emergency in which case you will be accompanied by a supervisor/volunteer/invigilator.
6. Do NOT disturb other competitors. If you need assistance, raise your hand and wait for a supervisor to come.
7. You can ONLY ask questions and discuss the experiments with your own team members. You must STAY at your table until the end of the time allocated for the experiments, even if you have finished the experiments or do not wish to continue.
8. At the end of the experiment time you will hear the “STOP” signal. Do NOT write anything more on the answer sheet after this stop signal. Arrange the exam, answer sheets, and the stationary items (pen, calculator, ruler, and scrap paper) neatly on your desk. Do NOT leave the room before all the answer sheets have been collected.

EXPERIMENT INSTRUCTIONS

1. After the “START” signal, you will have 15 minutes to read the experiments. In this time, it is NOT allowed to conduct the experiment yet, or answer the questions.
2. After the first 15 minutes, another whistleblow will indicate that you can start the experiment and start answering question. From this moment you have three hours to complete the test.
3. Use only the pen and pencil provided by the organizers.
4. The total number of experiments is 3. Check if you have a complete set of the exam sheets (16 pages, page 4 - page 19) and answer sheets (28 pages - including the front page). Raise your hand, if you find any sheets missing.
5. Check that your name, code and country are filled in on your answer sheets and sign every page of the answer sheets. Raise your hand, if you find any sheets missing.
6. Read the experimental procedures and questions carefully and write your answers in the corresponding boxes of the answer sheets.
7. When units are provided in the answer sheets, you have to write the answers correctly for the units.
8. Always show your calculations if room for this is provided. If you do not show your calculations, no points are awarded for the question.
9. You should write your final answers down in the appropriate number of digits.
10. You MUST wear a **Lab Coat** and **Safety Glasses** during the experiments.
11. You will be provided with two sets of translated answer sheets. Only the **YELLOW** answer sheets will be evaluated. You can split up the white answer sheets among your team and use them as scrap paper, but they will NOT be evaluated.
12. The **YELLOW** answer sheets should be kept behind the cardboard shield.
13. The number of points that can be obtained is indicated for each question.
14. Use of micropipette (Gilson pipette):
 - a) Set the volume with the thumb wheel. Maximum volume for P1000 is 1000 μL (indicated by a red one (1) and two black zeros (0), the bars on the last wheel indicate the third decimal); for P20 the maximum is 20 μL . (Black two (2), black zero (0) and red zero (0)). **Do not exceed the maximum volume!**
 - b) Fit the pipette tip to the pipette.
 - c) Push the pushbutton until the first stop.
 - d) For liquid take up: insert tip under liquid level and slowly release the pushbutton.
 - e) For liquid dispensing: place tip in another container and push the pushbutton until the second stop.
 - f) Remove the tip.

Biology - The contractile vacuole of *Paramecium*

Introduction

Paramecia are one of the best known and most studied types of unicellular organism. The shape of a *Paramecium* cell somewhat resembles a slipper, although the front is located at the 'heel' and the back at the 'toes' of the slipper (Figure 1).

Paramecia are mostly cultivated in 'hay infusion' (water in which hay has been boiled for about ten minutes). Bacteria feed on the degradation products of the hay and readily grow in this medium. *Paramecia* in turn consume the bacteria, allowing them to thrive in the medium as well.

Paramecia contain some interesting cell organelles named 'contractile vacuoles'. These vacuoles are used to pump water out of the cell.

In this experiment, you will investigate the contraction frequency of the anterior (= 'at the front') contractile vacuole of *Paramecium caudatum* for two salt concentrations of the surroundings.

➤ Read the protocol and answer question 1 on the answer sheet.

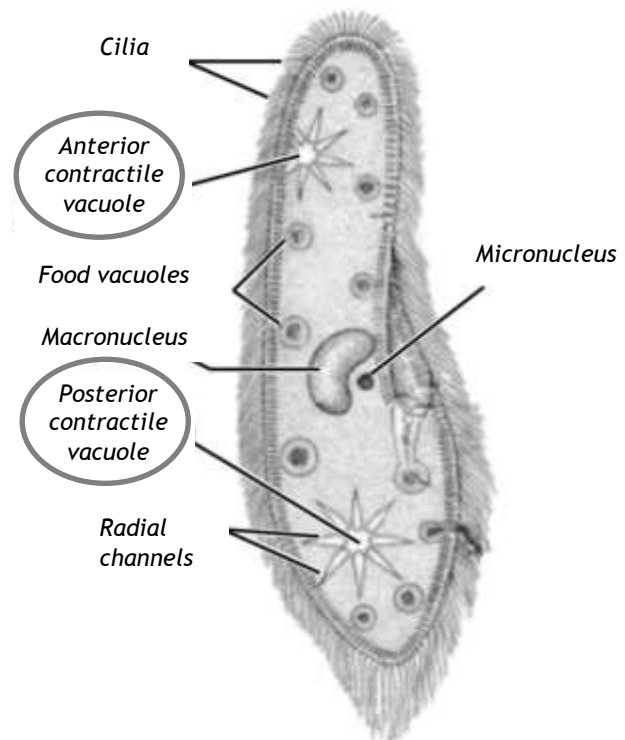

Figure 1 - Schematic drawing of a *Paramecium* cell with contractile vacuoles and some other cell organelles indicated.

Protocol

Investigation of the contraction frequency of the anterior contractile vacuole

To be able to investigate the contraction frequency of *Paramecium's* anterior contractile vacuole, you must study live *Paramecia* under the microscope. For this, you will prepare your own microscopy samples following these steps: First, you will concentrate the *Paramecia* from the hay infusion (section A). Then, you will prepare a microscopy sample of the concentrated *Paramecium* culture (sections B and C). Finally, you will analyse the *Paramecia* under the microscope (section D).

ATTENTION! It is important that the *Paramecia* in the microscopy samples are as fresh as possible when you analyse them. Therefore, perform all sections (A, B, C and D) for one salt concentration before moving on to the other salt concentration.

ATTENTION! It is possible that some *Paramecia* do not survive the preparation of the microscopy sample. Do not analyse *Paramecia* that are not healthy (swollen or shrunken or with protruding vesicles), that do not show any movement at all or whose vacuoles contract less than once per minute. If your sample does not contain enough healthy *Paramecia*, you have to make a new sample. You are allowed to use more than one droplet for your observations.

Materials

- A 50 mL Erlenmeyer flask with water
- A plastic 15 mL tube labelled 'P–', containing a *Paramecium* culture in hay infusion *without any additions*
- A plastic 15 mL tube labelled 'P+', containing a *Paramecium* culture *with extra sodium chloride added to increase the salt concentration by 0.03 mol/L*
- A 15 mL tube rack
- An empty 1.5 mL microcentrifuge tube labelled with 'P–' and your group number
- An empty 1.5 mL microcentrifuge tube labelled with 'P+' and your group number
- An empty 1.5 mL microcentrifuge tube labelled '•'
- Three spare microcentrifuge tubes
- A P1000 micropipette with blue pipette tips
- A P20 micropipette with yellow pipette tips
- A microcentrifuge, at one side of the lab, managed by a supervisor
- A plastic 15 mL tube labelled 'G–', containing methylcellulose gel *without any additions*
- A plastic 15 mL tube labelled 'G+', containing methylcellulose gel *with added sodium chloride to a concentration of 0.03 mol/L*
- A microcentrifuge rack
- Microscopy slides
- Cover slips
- A microscope
- A stopwatch
- A small waste bin
- Dissection needle

Experimental Procedure

A. Concentrating *Paramecia*

1. Use a P1000 micropipette to transfer 1.5 mL water to the microcentrifuge tube labelled '•'. Tightly close the tube with the attached cap.
2. Use a P1000 micropipette to transfer 1.5 mL *Paramecium* culture from the 15 mL tube labelled 'P–' to the 1.5 mL microcentrifuge tube with the same label. Tightly close the tube with the attached cap.
3. Have a supervisor centrifuge the microcentrifuge tube labelled with 'P–' and your group number, and the tube labeled '•' for 3 minutes at 3000 rpm. The tube labelled with '•' is used as counterbalance.
4. Obtain the centrifuged tubes. The *Paramecia* are now collected in a so-called 'pellet', at the bottom of the tube with your group number, a little to the side of the tube where the cap attaches (see Figure 2).
5. Set the P1000 micropipette to 1 mL and, *immediately* after centrifugation, extract 1 mL of the supernatant (the liquid above the pellet) from the microcentrifuge tube. Take care NOT to take up the pellet, so do NOT put the pipette tip at the bottom of the tube! Dispose of the 1 mL of supernatant in a sink.
6. Close the tube and firmly tap the bottom of the tube a couple of times with your finger to resuspend the *Paramecia*. After that, make sure all liquid is collected at the bottom of the tube again.
7. You now have 0.5 mL concentrated *Paramecium* suspension. Every time when using this suspension for preparing a microscopy sample, **first tap it with your finger to homogenise.**



Figure 2 - Schematic drawing of a microcentrifuge tube with a pellet (grey area).

B Preparing a microscopy sample for inspection by a supervisor

1. Set your P20 micropipette to 5 μ L and leave it at this setting. Use this micropipette to place 4 droplets of 5 μ L of the concentrated *Paramecium* suspension on a microscopy slide, as shown in Figure 3.
2. Place the microscopy slide with the droplets on the stage of the microscope.
3. Use the correct procedure to magnify the sample 40x (10x ocular lens and 4x objective) and make sure a *Paramecium* is in focus.
4. *Raise your finger to attract the attention of a supervisor. He or she will inspect your sample and award points in question 2 depending on your preparations.*
5. After your sample has been inspected, **read question 3 on the answer sheet**, but do not answer it yet until after performing section D. Magnify the sample 100x and observe the *Paramecia*.

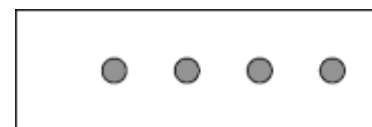

Figure 3 - schematic drawing of a microscopy slide with 4 droplets.

C. Preparing a microscopy sample for analysis

1. Use the P20 micropipette to place a total of 25 μL of the methylcellulose gel from the tube labelled 'G–' in the middle of a microscopy slide. ATTENTION: move the plunger of the pipette in a *slow* manner to avoid air bubbles in the tip.
2. Now, again use the P20 micropipette to take up 5 μL of the *Paramecium* suspension and carefully deliver it into the gel droplet on the microscopy slide.
3. Use a dissection needle to carefully but thoroughly mix the *Paramecia* with the gel. Try to prevent the droplet from spreading over the slide and try to prevent the formation of air bubbles.
4. Carefully place a coverslip on the gel droplet, but *do NOT press it!* Your microscopy sample is now ready for use.

D Observing Paramecia

1. Place the microscopy slide with the sample on the stage of the microscope.
2. Use the correct procedure to magnify the sample 100x.
3. Take a good look at the *Paramecia*.

➤ Answer question 3.

The *Paramecia* have two contractile vacuoles, one at the front (the anterior contractile vacuole) and one at the back (the posterior one) of the cells (see Figure 1). During the entire experiment, observe the **anterior** contractile vacuoles.

4. Observe six consecutive contractions of the anterior vacuole of a *Paramecium*. Note down the total time between contraction 1 and contraction 6 in **Table A2 in question 4** on your answer sheet. Repeat this for eight more *Paramecia*.

Repeat the procedures in sections A, C and D for the *Paramecium* culture with the higher concentration labelled 'P+'. You do NOT have to get your sample checked, i.e. you should skip section B completely. In section C, use the methylcellulose gel from the tube labelled 'G+' instead of the 'G–' gel.

➤ Answer questions 5-12.

Chemistry - Determining the concentration of a sodium chloride solution using the Fajans titration procedure

Introduction

Sea water contains about 35 g of salts per liter, most of which is sodium chloride. From the difference in salt concentrations between sea water and fresh water, electrical energy can be generated using so-called 'blue energy' techniques.

Weighing titration

To determine the chloride concentration of water, a technique that is called *weighing titration* can be employed.

In a 'normal' (volumetric) titration, a solution of a substance X with an unknown concentration is pipetted into an Erlenmeyer flask. An indicator is added and the solution of X in the Erlenmeyer flask is *titrated* with a second solution with a known concentration of reagent by slowly adding this solution from a burette. When the indicator changes colour, the end point of the titration is reached and the concentration of substance X can be calculated from the volume of the solution of X, the volume of the reagent solution that was added, the concentration of the reagent solution, and the ratio in which the substances react with each other.

In a *weighing titration* both the solution of X and the reagent solution are contained in syringes. Both syringes are weighed before the titration is started. Then, a certain amount of the solution of X is transferred from its syringe into an Erlenmeyer flask. An indicator is added and the solution of X in the Erlenmeyer flask is *titrated* with the second solution with a known concentration of reagent by slowly adding this solution from the second syringe. When the indicator changes colour, the end point of the titration is reached and both syringes are weighed again. The concentration of substance X can be calculated from the densities of both solutions, the masses of the solutions that were transferred to the Erlenmeyer flask, the concentration of the reagent solution, and the ratio in which the substances react with each other.

Importantly, in a weighing titration, it is very easy to correct for adding too much reagent solution ('overshooting the end point') by adding a bit of the solution of X again until the indicator has regained its original colour and then titrating the solution again with the reagent solution. Both syringes are only weighed when the end point has been reached exactly.

The experiment

In this experiment, you will use the so-called Fajans titration to determine the concentration of a solution of sodium chloride (NaCl). The Fajans titration involves titrating the sodium chloride solution with a solution of silver nitrate (AgNO₃), resulting in a white precipitate according to the following reaction:

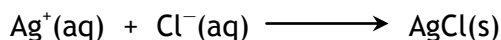

Some dextrin (a kind of starch) is added to prevent the precipitate from coagulating too much. Dichlorofluorescein functions as the indicator. It changes from yellow to pink when the end point of the titration is reached.

Materials

ATTENTION! The amounts of provided materials, detailed in the list below, are more than sufficient to carry out the experiments in full. In case you inadvertently spill, break or use too much of something, replacement / replenishment is available, but it will cost you and your team **one full mark** out of the thirteen you can earn for this experiment. The only exception is demineralized water, which you can obtain at no cost in marks by handing in your empty bottle to a supervisor. You will receive a full bottle in return.

- A 250 mL or 300 mL Erlenmeyer flask
- Two 50 mL beakers
- Two 20 mL plastic syringes
- Two blunt needles
- A small spatula
- A P1000 micropipette
- A pipette stand
- Two blue micropipette tips
- Paper towels
- A waste canister, labelled 'Waste'
- A permanent marker pen
- Disposable gloves (available from boxes at a central point in the lab)
- A cardboard cover for the table
- A plastic bottle, labelled 'NaCl', containing 100 mL of a sodium chloride solution of unknown concentration
- A black plastic bottle, labelled 'AgNO₃', containing 75 mL of a **20.00 g/L** silver nitrate solution
- A 15 mL centrifuge tube, labelled 'DCF', containing a 1 mg/mL solution of dichlorofluorescein in 96% ethanol
- A centrifuge tube rack
- A wash bottle with demineralized water
- A capped glass vial, labelled 'Dextrin', filled with dextrin
- Two 10 mL glass vials
- An accurate scale (shared by two teams)
- A 1.0 mL disposable plastic pipette with scale marks (see Figure 1 below)

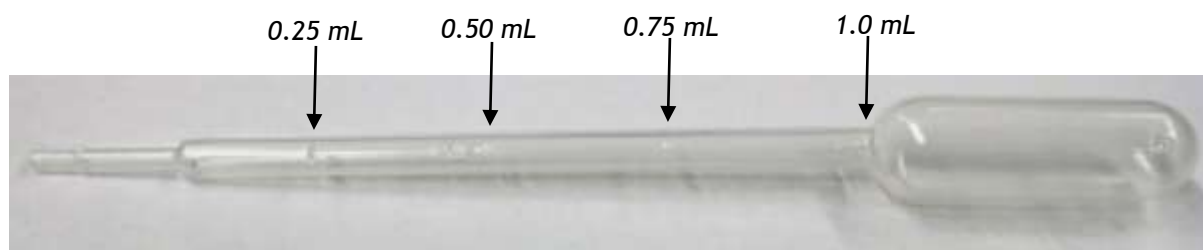

Figure 1 - A disposable plastic pipette with scale marks indicated by arrows.

Data

In table 1 below, you can find the standard atomic weights of some elements:

Table 1 - *Standard atomic weights of some elements*

Element	Standard atomic weight
N	14.01
O	16.00
Na	22.99
Cl	35.45
Ag	107.87

Safety precautions

ATTENTION! You are required to wear gloves during the entire experiment. Although the solutions used are quite harmless, spilled silver nitrate solution can lead to ugly brown spots on your skin. The same holds for your clothes, the table and the floor, so try to prevent spilling the solution and, if you accidentally spill something, clean up any droplets immediately with a paper towel.

- Before using the solutions of NaCl and AgNO₃ pour them in a beaker.
- Do not attempt to remove any air bubbles out of the syringes.

A. Determining the densities of the solutions

Use the scale, the micropipette (and tips!) and the glass vials to determine the densities of the solutions of sodium chloride and silver nitrate. Make sure that you obtain highly accurate values for the densities of the solutions! **Write your measurements, calculations and answers on the answer sheet.**

B. A trial titration

Goals

The trial titration has two goals:

- estimating the approximate volume of silver nitrate solution that needs to be added to a certain amount of the sodium chloride solution to reach the end point.
- observing the colour change of the indicator at the end point. Note that the colour of the yellow solution gradually becomes somewhat orange; this is NOT the end point of the titration. The end point is reached when the yellow-orange colour of the suspension has **just** (i.e. with the addition of a single droplet) clearly changed to pink and remains pink also after you thoroughly swirled the contents of the Erlenmeyer flask.

Procedure

1. Equip one of the syringes with a blunt needle.
2. Fill the syringe up to the **15 mL** mark with the sodium chloride solution.
3. Dry off any liquid on the outside of the syringe and the needle, also from the needle tip. Do not worry about the air bubble in the syringe.
4. Carefully empty the syringe into the 250 mL Erlenmeyer flask.
5. Add about 85 mL of demineralized water to the solution in the Erlenmeyer flask.
6. Add three spatulas full of dextrin to the Erlenmeyer flask. Swirl the flask to suspend the dextrin.
7. Use the disposable pipette to add about 0.5 mL of dichlorofluorescein solution to the Erlenmeyer flask.
8. Equip the other syringe with the second blunt needle.
9. Fill the syringe up to the **20 mL** mark with silver nitrate solution.
10. Dry off any liquid on the outside of the syringe and the needle, also from the needle tip.
11. Now, titrate the sodium chloride solution with the silver nitrate solution by adding silver nitrate solution to the sodium chloride solution in the Erlenmeyer flask while constantly or intermittently swirling the contents of the flask. Keep adding silver nitrate solution until you have reached the end point
12. Read off the remaining volume of silver nitrate solution in the syringe and calculate the volume of silver nitrate solution that you have added.
13. If you like, you may experiment a little by adding a few droplets of sodium chloride solution again, followed by some droplets of silver nitrate solution, so you get an idea of the principle of weighing titration.
14. When you are finished, pour the suspension from the Erlenmeyer flask into the waste canister. Thoroughly rinse the Erlenmeyer flask three times with demineralized water. Also pour the rinsings into the waste canister.

C. Accurate titrations

ATTENTION! To accurately titrate the sodium chloride solution, it is important that you add the indicator solution only **just before** the end point of the titration is reached.

Procedure

1. Fill the first syringe up to the **20 mL** mark with the sodium chloride solution.
2. Dry off any liquid on the outside of the syringe and the needle, also from the needle tip.
3. Weigh the syringe in the upright position with the solution. **Write the initial mass on the answer sheet.**
4. Carefully empty the syringe **down to the 5 mL mark** into the 250 mL Erlenmeyer flask. So, only expel about 15 mL from the syringe; it is important that some sodium chloride solution remains in the syringe!
5. Add about 85 mL of demineralized water to the Erlenmeyer flask.
6. Add three spatulas full of dextrin to the Erlenmeyer flask. Swirl the flask to suspend the dextrin.
7. Fill the second syringe up to the **20 mL** mark with silver nitrate solution.
8. Dry off any liquid on the outside of the syringe, also from the tip.
9. Weigh the syringe with the solution. **Write the initial mass on the answer sheet.**
10. Now, titrate the sodium chloride solution with the silver nitrate solution until you are about 1 mL away from the end point.
11. Use the disposable pipette to add 0.5 mL of dichlorofluorescein solution to the Erlenmeyer flask.
12. Complete the titration.
13. When you are satisfied that you have exactly reached the end point, weigh both syringes and **write down their final masses on the answer sheet.**
14. When you are finished, pour the suspension from the Erlenmeyer into the waste canister. Thoroughly rinse the Erlenmeyer flask three times with demineralized water. Also pour the rinsings into the waste canister.

Repeat the accurate titration two times (so three accurate titrations in total). **Then work out the questions on the answer sheets.**

Physics - Blue energy

Introduction

In 1932, in the Netherlands, a dyke was built that dammed off the former Southern Sea from the Wadden Sea (Figure 1). That dyke, called the Closure Dyke, caused the former salty Southern Sea to become the fresh-water Lake IJssel, named after the river IJssel that feeds it. To regulate the water level in the lake, water is drained through the Closure Dyke into the Wadden Sea at low tide.

From the difference in salt concentrations between sea water and fresh water, electrical energy can be generated. The general name for electrical energy generated from differences in salt concentration is 'Blue energy'. One of the ways to generate electrical energy in an energy power plant is called 'Reverse ElectroDialysis' (RED). In such a plant, salt and fresh water are physically separated by membranes that allow either positively charged ions or negatively charged ions to pass through. Due to the

concentration difference, ions from the salt water migrate to the fresh water. This charge transport can be used to generate electricity. Blue energy is a renewable source of energy that does not result in the production of greenhouse gases such as CO₂, NO_x and SO_x.

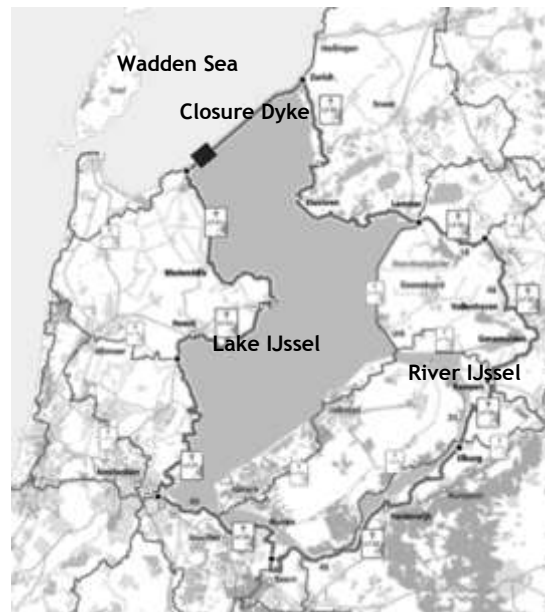

Figure 1 - The Lake IJssel with the Closure Dyke in the North. The contours of the former Southern Sea are indicated by the bold line.

Goals and experimental setup.

You will use two experimental setups to generate results that you can use to estimate how much energy can maximally be generated from the difference in salt concentrations between using a Blue Energy power plant. The complete experiment consists of three parts:

A. Setup A: The concentration cell

You will use this setup to measure the voltage (= the electric potential difference) between salt solutions of different concentrations.

B. Setup B: Conductivity

You will use this setup to measure the electrical conductivity of the different salt solutions.

C. Carrying out a number of calculations.

Equation sheet

Ohm's law:

$$\Delta V = I \cdot R$$

Electrical conductance:

$$G = \frac{1}{R} ; \text{ unit is siemens: } [G] = S = \Omega^{-1}$$

Specific electrical conductivity:

$$\sigma = G \frac{l}{A}$$

Electrical power

$$P = \Delta V \cdot I$$

Circumference of a circle:

$$2\pi r$$

Area of a circle:

$$\pi r^2$$

A. Measuring potential differences using the concentration cell

Goals of the experiment

1. Measuring the potential differences between solution X0 and solutions X1 – X4.
2. Determining the concentration of solution X0.

The experiment

Setup

A photograph of the experimental setup is provided in Figure 2 (start situation).

Materials

- Two beakers of 100 mL (indicated by A in Figure 2)
- A stand with clamps
- A salt bridge (B)
- Two silver/silver chloride electrodes (C)
- A plastic holder for the salt bridge and the electrodes (D)
- A digital multimeter
- A red electrical wire
- A black electrical wire
- One 250 mL flask labeled X0, containing a salt solution of unknown concentration
- Four 250 mL flasks labeled X1 to X4, containing salt solutions of different known concentrations. (Note: you also need these flasks in experiment B)
- A list of concentrations is provided with the setup.
- Paper towels

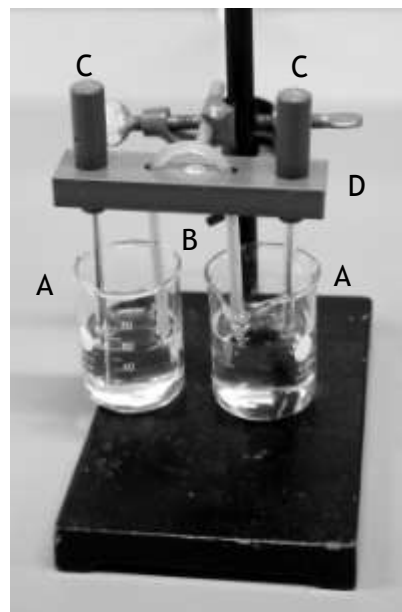



Figure 2 - Experimental setup, start situation

ATTENTION!

Be careful using the electrodes! Always store them with their wires in a salt solution except while changing solutions. Do not rinse them with demineralized water.

Do NOT use the Ω -position of the multimeter switch, the silver chloride electrodes will be severely damaged and thereafter useless.

If the multimeter beeps, press the RANGE button to prevent it from switching off. If it switched off, turn the dial to OFF and then back to mV 

If you have any other problems regarding the multimeters, please contact the lab assistants.

Performing the experiment

At the start of the experiment the setup is as depicted in Figure 2. The salt bridge and electrodes are both submerged in salt solution X0. During the experiment the content of the left beaker is replaced by solutions X1 to X4, the right beaker stays filled with the X0 solution.

1. Set the dial of the multimeter to mV \equiv and press the blue button to select direct current (DC).
2. Connect carefully the right electrode with the red electrical wire to the $V\Omega$ port of the multimeter and the left electrode with the black electrical wire to the COM port of the multimeter.
3. Wait until the multimeter indicates a reasonably stable voltage. Write down the voltage in table A1 on the answer sheet (Note: the voltage can have a positive or negative value). *If the voltage is larger than 3 mV (or less than -3 mV), ask the lab assistant for a new set of electrodes!*
4. Raise the clamp with holder such that the salt bridge and electrodes are removed from the solutions. Empty the *left* beaker in the sink. Dry the inside of the beaker thoroughly with a paper towel.
5. Pour approximately 80 mL of solution X1 in the beaker and place it back on the stand base.
6. Lower the clamp with the holder such that the salt bridge and electrodes properly hang in the solutions again.
7. Wait for the voltage to stabilize (max 5 minutes), you can gently shake the beakers during this period. Write down the voltage in table A1 on the answer sheet.
8. Repeat steps 4 to 7 for solutions X2, X3 and X4.
9. When you are finished, leave the setup with the electrodes and salt bridge hanging in the solutions, disconnect the electrical wires and switch off the multimeter. Ask the lab assistant to pick up the electrodes and salt bridge for safe storage. If you need the electrodes later again, you can ask for them.

➤ **Answer questions 1 to 5 on the answer sheets.**

B. Measuring the electrical conductance of the solutions

Goals of the experiment

- Measuring the electrical conductance of solutions X0 and X1–X4.
- Determining the concentration of X0.
- Determining the specific electrical conductivity of X0 and X1–X4.

The experiment

Materials

- Two beakers of 100 mL
- A set of two gold-plated electrodes (part A in Figure 3)
- AC power supply box (B) (without cable)
- Two digital multimeters (C)
- Four 250 mL flasks labeled X1 to X4, containing salt solutions of different concentrations (the same flasks as in part A)
- One 250 mL flask labeled X0, containing a salt solution of unknown concentration
- Paper towels
- One set square (in your pencil case)
- Four electricity wires (red, black, 2x blue) (D) and two wires of a multimeter (red, black) (E)
- A stand with clamps

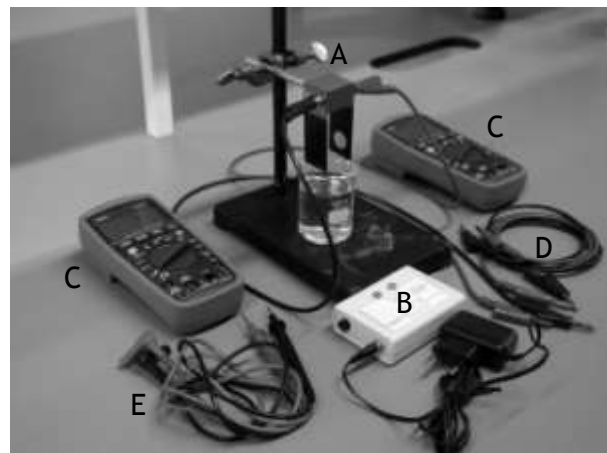



Figure 3 - Materials for the setup of the experiment

Setup

In this experiment the electrical conductance of the salt solutions will be determined with the materials depicted in Figure 3. A set of gold plated electrodes is submerged in a beaker containing the salt solution. The electrodes must be connected to a power supply, which delivers an alternating voltage with a high frequency (1 kHz) and a low voltage. This is needed to prevent electrolysis of the salt solution. From the measurement of voltage across and current through the electrodes the electrical conductance can be determined. In Figure 4 a schematic of the power supply is shown, with the AC voltage supply depicted as the box with the triangle shaped symbol. During the experiment we will connect the ports on the right side with the electrodes for the conductance measurements. In order to measure the current, the box contains a resistor $R_1 = 10 \Omega$ and an amplifier to amplify the voltage across the resistor 10 times. The output is measured between the two upper ports.

Performing the experiment

1. Pour 80 mL of solution X0 in both beakers. Beaker 1 will be used for measurements, beaker 2 for rinsing with X0 in between measurements.
2. Submerge the set of electrodes in beaker 1 such that the circular gold plated surfaces are fully submerged in the solution.
3. Build the electrical circuit using the schematic from Figure 4. Make sure the multimeters are in the mV  AC setting (using the blue button so that 'AC' appears in the display) for alternating current, and connected to the appropriate sockets.

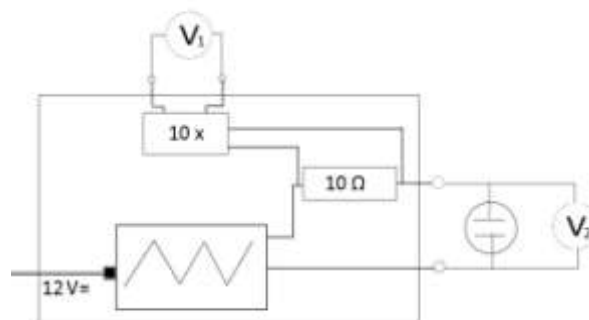



Figure 4 - Schematic of the power supply box. The symbol  is used for the electrodes.

Ask a lab assistant to check your circuit and to connect your power supply.

Let the lab assistant sign the answer sheet before proceeding with the experiment!

4. Now plug the power supply in the wall socket and wait a moment until both multimeters show a more or less constant value. If the reading of a multimeter is “OL” (out of limit), change the range with the RANGE button, or turn the dial to V~. Write the values in Table B1 at question 7 on the answer sheets, and complete the symbols of the measuring quantities with the correct units in the top row.
5. Lift the electrodes out of beaker 1, and lower them in beaker 2 for rinsing.
6. Pour the contents of beaker 1 down the drain and dry the inside of the beaker.
7. Fill beaker 1 with solution X1.
8. Take the electrodes out of the clamp, shake them gently and put them back in beaker 1 in the same way as at step 2. Take the readings from the multimeters and write them down in Table B1 at question 7 on the answer sheets.
9. Repeat the measurements (steps 5 – 8) for the remaining solutions X2, X3, and X4. Write down the readings on the answer sheet.
10. Finally, remove the power supply from the wall socket. Clean the beakers and electrodes.

➤ Answer questions 8 to 10 on the answer sheets

The conductance you measured is dependent on the distance between the electrodes and the area of the conducting surface. The *specific conductivity*, however, is a property of the solution and does not depend on the setup used. The relationship between conductance and specific conductivity σ is:

$$\sigma = G \cdot \frac{l}{A} \quad \text{in S/m.}$$

In this equation l is the distance between the electrodes and A the conductive area of the electrodes. In the cell you used this is the area of the gold plated circle.

➤ Answer questions 11 and 12 on your answer sheets.

C. Calculating the theoretical maximum electrical power

Goal

- Calculating the theoretical maximum power produced by a RED Blue Energy cell.

In the previous sections we have obtained information on the obtainable voltage from a concentration cell, and the electrical conductivity of salt solutions. Using these data we will now calculate how much electrical power a Blue Energy power plant could produce in theory.

In Figure 5 the schematic of a RED Blue Energy cell is depicted. It consists of two large flat electrodes and a membrane in between. This membrane has the same functionality as the salt bridge in setup A. Salt water flows on one side of the membrane, and fresh water on the other side. This creates a potential difference between the electrodes in the same way as measured in setup A. The electrodes can be connected to an external resistor R_{ext} to generate current and power.

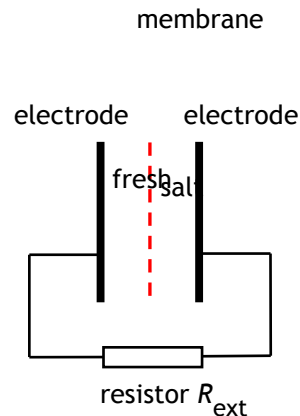

Figure 5 -Schematic RED Blue Energy cell

In the following part of this exercise you are going to calculate the maximum power a Blue Energy cell could deliver, on basis of your own measurements.

- Answer question 13 on your answer sheets.

For the RED cell the distance between the electrodes and membrane is equal to $l = 2.0 \text{ mm}$ and the total area of the electrodes is $A = 1.0 \times 10^2 \text{ m}^2$.

The internal resistance of the RED cell can be calculated as follows:

$$R_{\text{int}} = \frac{1}{G_{\text{fresh}}} + \frac{1}{G_{\text{salt}}}$$

- Answer questions 14 and 15 on your answer sheets.

To obtain the maximum power from the RED cell, connect it to an external resistor with an equal resistance as the internal resistance:

$$R_{\text{ext}} = R_{\text{int}}$$

- Answer questions 16 to 18 on your answer sheets.